

IKA®

Pilots From Lab to Production



designed
to work perfectly

**IKA®-Werke GmbH & Co. KG in Staufen,
Germany can now look back on a century
of history.**

IKA® is a leading manufacturer for process equipment as well as in laboratory and analyzing technology with worldwide subsidiaries.

The product range of the three business fields leads from the laboratory stirrer over analyzing equipment to production size machines for dispersing, stirring and kneading up to complex, individually designed plants.

IKA® Pilots connect your lab with the large-scale production. IKA® ensures a seamless transition from product development to mass production by offering an equipment series where the same machine can handle both small and large capacities.

For more information, please visit:

www.ika.com

and

www.ikaprocess.com



www.facebook.com/IKAworldwide



| Where the industry's future begins

Executed in IKA® quality

Every single IKA® product is submitted to a final product quality test before it leaves our facility. An operational test and complete inspection ensures that every machine will be easily integrated into the customer's plant.



Why IKA® pilots make you rise to the top.

New products and formulations being developed in laboratories all over the world carry the IKA® signature. When it comes to subsequent production, IKA® high-duty systems are once again in use on the front line.

Additionally IKA® offers a one-stop, smooth transition of formulations and technologies from laboratory to the large-scale production, thereby confirming pilot systems as an indispensable link. Results acquired in the laboratory, translate from process and recipe development to production scale in a consistently reliable manner.

Pilots that are used in the test center play a significant role in determining whether a product will be successful or not. Here, the process technology to be used is defined, the required machine or system size is determined and the necessary energy requirements are established. Furthermore, the quality and volume of the raw materials and selection of optional additives, such as emulsifiers, can be determined.

IKA® pilots therefore have a direct influence on the quality and character of the final product.

IKA® pilots allow you to:

- > choose the process technology to be used
- > define the required machine and system size
- > establish the necessary energy requirements
- > determine the quality and volume of the raw materials that will be used
- > calculate and define the final products quality standard
- > determine the flow or batch times of the industrial system

IKA® offers the following first-rate products that can be used for numerous mixing tasks in continuous and discontinuous operations.



4



Agitators

Reliable helpers get things moving in the test center

IKA® stirrers, designed for the stirring of volumes between laboratory and production amounts, are ideal for speeding up solution processes, for synthesis, temperature exchanges within the medium and the mixing of easily mixable liquids and solids.

8



Batch dispersing machines

Efficient processes for every approach

IKA® batch dispersers are used for applications where conventional stirring is just not enough. For example, when it comes to emulsions and fine suspensions. Thanks to the built-in rotor-stator system, they assure a high product recirculation as well as a good dispersing quality with a comparatively low energy demand.

12



Inline dispersing machines

Ideal results, non-stop

They are small, but configured just like their respective production machines. The unique design, with a single drive unit, seven exchangeable modules and two upgrade choices enables continuous mixing, emulsifying, suspending, powder incorporation as well as the processing of products during the recirculation operation.

17



Laboratory reactors and pilot plants

Achieving a lot while still in the laboratory

IKA® laboratory reactors and pilot plants are just as functional as industrial batch systems. The development of new products or recipe improvements are easier now, because everything can be done in one batch: Stirring, dispersing, mixing, heating/cooling and evaporating.

IKA® Pilots | Magnetic stirrers

IKA®+

Magnetic stirrers series MR 1

Powerful magnetic stirrer without heating. Casing and bottom plate made of stainless steel. Infinitely adjustable speed. Magnetic stirring bar IKAFLON® 50 included.

Midi MR 1 digital

for mixing volumes up to 50 l (H₂O)

Technical data

Power supply	230 V / 50 Hz
Rotational speed range	0 – 1,000 rpm
Speed display	digital
Timer	0 – 56 min
Dimensions (W x D x H)	360 x 430 x 110 mm
Set-up plate dimensions	350 x 350 mm
Weight	10.7 kg

Midi MR 1 digital

Ident. No. 0002621900



Maxi MR 1 digital

for mixing volumes up to 150 l (H₂O)

Technical data

Power supply	230 V / 50 Hz
Rotational speed range	0 – 6,000 rpm
Speed display	digital
Timer	0 – 56 min
Dimensions (W x D x H)	505 x 585 x 110 mm
Set-up plate dimensions	500 x 500 mm
Weight	16 kg

Maxi MR 1 digital

Ident. No. 0002621800



IKA® Pilots | Overhead stirrers

RW 28 digital

Powerful, mechanically controlled laboratory stirrer designed for highly viscous applications for quantities up to 80 l (H₂O).

RW 28 digital	
Technical data	
Power supply	220 – 240 V / 50 – 60 Hz
Motor power	220 / 90 W
Max. viscosity	50,000 mPa·s
Speed range (at 50/60 Hz)	60 – 1,400 rpm/72 – 1,680 rpm
Speed range II (at 50/60 Hz)	60 – 400 rpm/72 – 480 rpm
Max. torque at stirring shaft	240 – 1,400 rpm/288 – 1,680 rpm
Dimensions (W x D x H)	123 x 252 x 364 mm
Weight	7.5 kg

Package includes	Ident. No.
RW 28 digital (drive)	0005040000
R 271 Boss head clamp	0002664000
R 2723 Telescopic stand	0001412100
R 1385 Propeller stirrer	0000477700
RW 28 digital Package	0009023200



R 1385 Propeller stirrer,
3-bladed



R 271 Boss head clamp



R 2723 Telescopic stand



RW 47 digital

Extremely powerful, mechanically controlled laboratory stirrer designed for highly viscous applications for quantities up to 200 l (H₂O). It is suitable for intensive mixing for use in laboratories and test centers.

RW 47 digital	
Technical data	
Power supply	3 x 400 V
Motor rating input/output	513 / 370 W
Max. viscosity	50,000 mPa·s
Speed range (at 50/60 Hz)	57 – 1,300 rpm / 69 – 1,560 rpm
Speed range I (at 50/60 Hz)	57 – 275 rpm / 69 – 330 rpm
Speed range II (at 50/60 Hz)	275 – 1,300 rpm / 330 – 1,560 rpm
Max. torque at stirring shaft	3,000 Ncm
Dimensions (W x D x H)	145 x 358 x 465 mm
Weight	16 kg

Package includes	Ident. No.
RW 47 digital (drive)	0004050000
R 474 Telescopic stand	0001643000
R 2302 Propeller stirrer, 4-bladed	0000739000
RW 47 digital Package	0009023300



R 2302 Propeller stirrer,
4-bladed



R 474 Telescopic stand



IKA® Pilots | Agitators

Agitators IKA® TURBOTRON® RKG-00-Bo

Powerful, mechanically controlled agitators for intensive mixing with approval for use in Ex-Zone 1 (2G), temperature class T3 acc. to the ATEX 95 directive. Suitable for open or pressureless vessels. Exchangeable stirring tools.

*Cables not included in the delivery.

RKG-00-Bo 0,25 kW ATEX

for batches up to 80 l (H₂O)

RKG-00-Bo 0,25 kW ATEX	
Technical data	
Power supply	3 x 400 V / 50 Hz
Motor power	250 W
Max. viscosity	50,000 mPa-s
Torque at stirring shaft:	
at 20 – 600 rpm	approx. 300 Ncm
at 1200 rpm	approx. 150 Ncm
Rotational speed range	20 – 1,200 rpm
Dimensions (W x D x H)	237 x 296 x 515 mm
Weight	13.8 kg

Package includes	Ident. No.
RKG-00-Bo 0,25 kW ATEX (drive)	U084463
R 271 Boss head clamp	T056481
Adapter for fixing	U082537
Stirrer shaft protection	U069094
R 1385 Propeller stirrer	T060368
R 2723-ATEX Telescopic stand	U099027
RKG-00-Bo 0,25 kW ATEX Package	U098950



RKG-00-Bo 0,55 kW ATEX

for batches up to 200 l (H₂O)

RKG-00-Bo 0,55 kW ATEX	
Technical data	
Power supply	3 x 400 V / 50 Hz
Motor power	550 W
Max. viscosity	100,000 mPa-s
Torque at stirring shaft:	
at 20 - 600 rpm	approx. 600 Ncm
at 1200 rpm	approx. 330 Ncm
Rotational speed range	20 – 1,200 rpm
Dimensions (W x D x H)	196 x 333 x 550 mm
Weight	20 kg

Package includes	Ident. No.
RKG-00-Bo 0,55 kW ATEX (drive)	U087228
Adapter for fixing	U082537
Stirrer shaft protection	U069094
R 2302 Propeller stirrer	U082544
R 474-ATEX Telescopic stand	U092603
RKG-00-Bo 0,55 kW ATEX Package	U098955

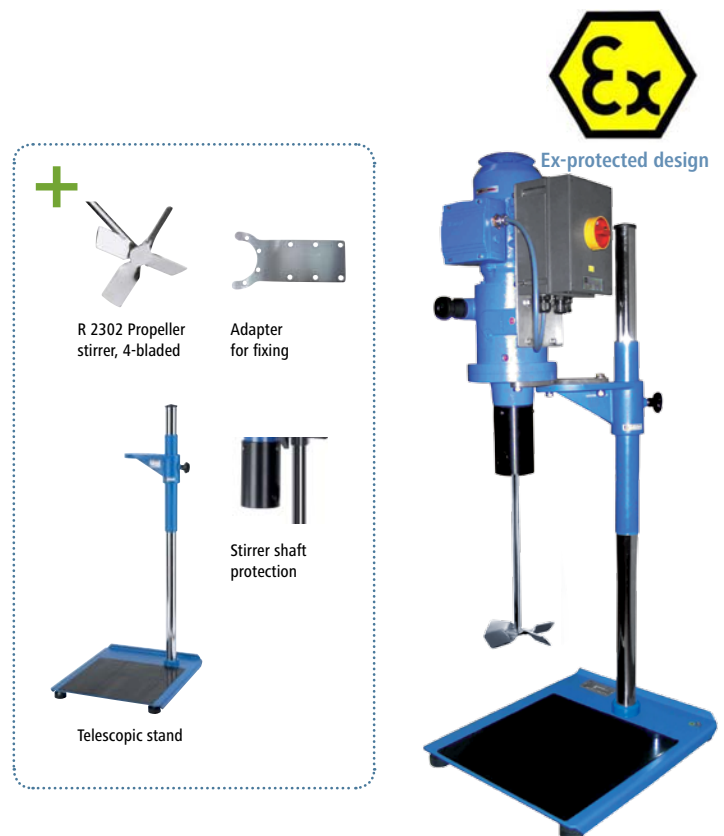



IKA® Pilots

IKA® Pilots connect your lab with the large-scale production. IKA® ensures a seamless transition from product development to mass production by offering an equipment series where the same machine can handle both small and large capacities.

The magic LAB®, LABOR-PILOT and PROCESS-PILOT machines are perfectly suited for the optimization of product recipes and process parameters.

IKA® pilot system Master Plant has batch capacities of 10, 25 and 50 litres. It is designed for mixing and dispersing processes, and provides effective suction of solid and liquid additives.

IKA® batch dispersing machines

Dispersing machines are ideal for materials that cannot be mixed. What a stirrer could not mix in hours, can be dispersed in just a few minutes with a batch disperser. The effectiveness of IKA® dispersing machines is based on the rotor-stator principle. The rotor's high circumferential speed creates the shear forces, which are required by solid particles or liquid drops to lead to their reduction. This is how emulsions and suspensions are created. IKA® offers dispersing machines for batches from 2 l up to 500 l with matching stands and optimal accessories.

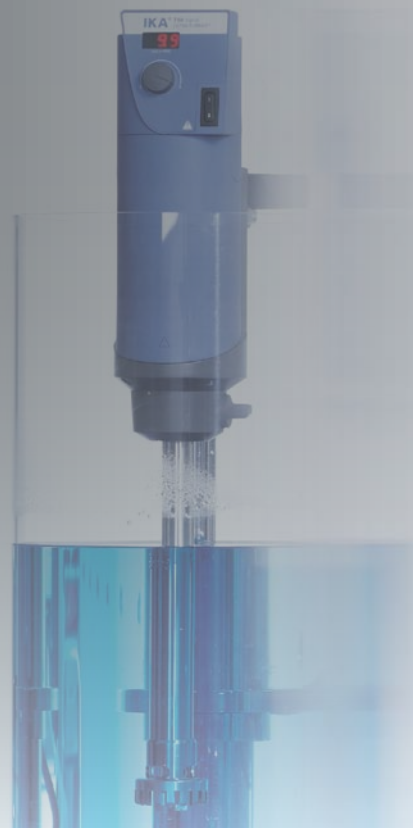

T 65 basic ULTRA-TURRAX®

Extremely powerful dispersing instrument for volumes from 2 – 50 l (H₂O).

A fixed speed of 7,200 rpm enables users to work at a high circumferential speed even with small rotor diameters. Three rotor-stator configurations guarantee a wide range of applications. Reproducible operations due to constant speed even with changes in viscosities.

Technical data		T 65 basic
Power supply		3 x 400 V / 50 Hz
Motor rating input/output		1,800 / 1,500 W
Max. viscosity		5,000 mPa·s
Volume range (H ₂ O)		2 – 50 l
Speed range		7,200 rpm (fixed)
Speed control		fixed
Noise without element		75 dB(A)
Dimensions (W x D x H)		185 x 400 x 450 mm
Weight		26 kg

Package includes	Ident. No.
T 65 basic (drive)	0004023500
Telescopic stand T 653	0001608000
S 65 KG-HH-G 65 G	0008005500
T 65 basic ULTRA-TURRAX®	0009023400
Package	



S 65 KG-HH-G-65 G
Dispersing tool



T 653 Telescopic stand





T 65 digital ULTRA-TURRAX®

Extremely powerful dispersing instrument for volumes from 2 – 50 l (H₂O) with digital speed display for the use in typical test centers.

It offers a wide speed range from 1,000 – 9,500 rpm that enables users to work at high circumferential speeds even with small rotor diameters. Three rotor-stator configurations guarantee a wide range of applications. Reproducible operations due to constant speed even with changes in viscosities.

T 65 digital	
Technical data	
Power supply	3 x 400 V / 50/60 Hz
Motor rating input/output	2,600 / 2,200 W
Max. viscosity	5,000 mPa·s
Volume range (H ₂ O)	2 – 50 l
Speed range	1,000 – 9,500 rpm
Speed control	stepless
Noise without element	75 dB(A)
Dimensions (W x D x H)	300 x 400 x 390 mm
Weight	29 kg

Package includes	Ident. No.
T 65 digital (drive)	0004234500
Telescopic stand T 653	0001608000
S 65 KG-HH-G 65 G	0008005500
T 65 digital ULTRA-TURRAX® Package	0009023500



S 65 KG-HH-G-65 G
Dispersing tool



T 653 Telescopic stand





Dispersing / Stirring

IKA® is the world leader in designing and manufacturing of high shear mixers and systems. IKA® produces a full range of mixers from laboratory to production scale. Our high shear mixers and dispersers feature our proven rotor-stator designs that are used in thousands of chemical, food, pharmaceutical and cosmetic companies.

The machines are designed to withstand the most demanding applications and provide ultimate flexibility for your application needs.

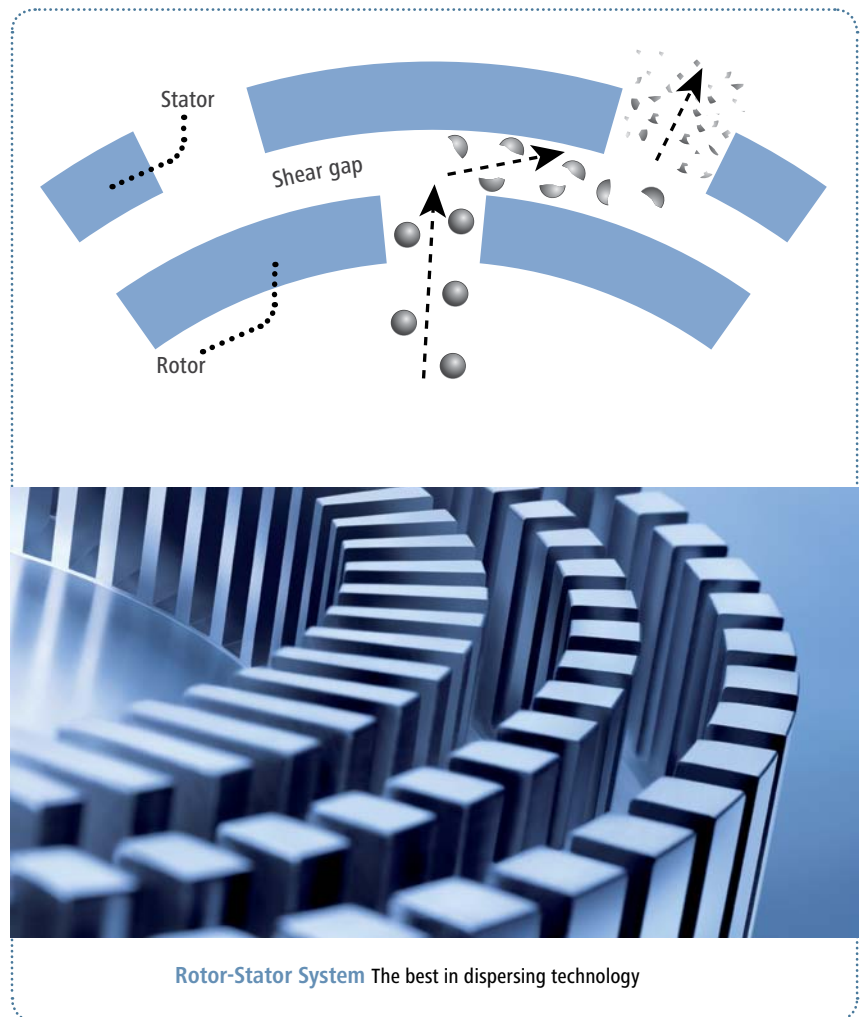

Rotor-Stator System The best in dispersing technology

IKA® ULTRA TURRAX UTC | Batch dispersing machine

UTC T 80/2-KT (w/o figure)

for batches from 25 up to 150 l (H₂O)

Powerful three phase asynchron motor with integrated frequency converter and potentiometer for speed adjustment.

Technical data		UTC T 80/2-KT
Power supply		3 x 380 – 420 V / 50 Hz
Motor power		3 kW
Max. viscosity		5,000 mPa·s
Temperature range ²		0 – 120 °C
Shaft length standard		650 mm
Rotational speed range		1,200 – 5,200 rpm
Circumferential speed		5 – 17 m/s
Dimensions (W x D x H)		250 x 298 x 953 mm
Weight		35 kg

Package includes	Ident. No.
UTC T 80/2-KT	U098985
SFH 75 Mobile stand	U091783
UTC T 80/2-KT Package	U098963

UTC TP 115/4-KT ATEX

for batches up to 500 l (H₂O)

Approval for use in the Ex-Zone 1 (2G), temperature class T3 acc. ATEX 95

Technical data		UTC TP 115/4-KT ATEX
Power supply		3 x 380 – 420 V / 50 Hz
Motor power		3 kW
Max. viscosity		5,000 mPa·s
Temperature range ²		0 – 120 °C
Shaft length standard		965 mm
Rotational speed range		3,000 rpm
Circumferential speed		15 m/s
Dimensions (W x D x H)		250 x 310 x 1,383 mm
Weight		45 kg

Package includes	Ident. No.
UTC TP 115/4-KT ATEX	U098986
SFH 150-ATEX Mobile stand	U067836
UTC TP 115/4-KT ATEX Package	U098965

Batch dispersing machines
IKA® ULTRA-TURRAX® UTC
High efficiency dispersion
machine for the production of
emulsions and suspensions.
The KT-version¹ is designed for
inclined or vertical installation
in open vessels.

*Cables not included in the delivery.



Ex-protected design

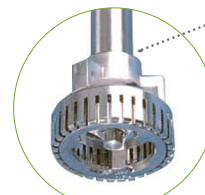

Dispersing tool



¹ On request the KD-version is available for closed vessels (up to 10 bar).

² Machines for operation in the temperature range from -40 °C to 160 °C are also available.
Execution for operation via frequency converter as well as electric control optionally possible

IKA® inline dispersing machines

Ideal results, non-stop

IKA® stands for the development of continuous mixing processes. Saving time, money and resources, while achieving an increased and stable product quality, are the advantages offered to you by IKA® inline dispersing machines. The magic LAB®, LABOR-PILOT and PROCESS-PILOT machines are perfectly suited for product development and process optimization and stand out by using the same specific energy input achieved by IKA® inline machines with higher flow rates. They allow for coarse and fine dispersions to be produced, as well as for powder to be fed into the liquid in a lump and dust free manner for being homogeneously mixed. The available accessories allow for these inline machines to be turned into laboratory and pilot mixing systems.



One machine for many mixing tasks



- > with double acting mechanical seal
- > for operation under pressure up to 10 bar and vacuum
- > for works at elevated temperatures
- > Ex-protected design available



IKA® magic LAB® 2000/03

Small inline dispersing laboratory machine for the production of emulsions and suspensions with extension capabilities for specific mixing tasks in the continuous and recirculation operation. Control and info center for adjustment and indication of speed, torque and temperature. Double-walled working chamber. Module ULTRA-TURRAX UTL with rotor-stator system 4M. All metal parts in contact with the product are made of stainless steel. Temperature sensor PT 100, transport box with wheels and drawers for various modules, telescopic handle and built-in power supply are included. Optional: Software labworldsoft for the control of the machine magic LAB from the PC, additional modules and tools, peripherals for extension into a batch plant.

IKA® LABOR-PILOT 2000/04

Inline dispersing machine in pilot size with upscale possibilities on the production scale. Three phase asynchron motor with V-belt drive. PTFE shaft seal. All metal parts in contact with the product are made of stainless steel. CIP-/SIP-capable. Standard execution with module UTL: Single stage dispersing chamber including rotor-stator system 4M. Exchangeable modules for special mixing tasks as well as accessories for extension into a system working in recirculation available. Can be delivered with on/off switch or with LABOR-PILOT CONTROLLER for variable speed adjustment.

IKA® PROCESS-PILOT 2000/04

Inline dispersing machine in pilot size; suitable for working under vacuum/pressure and at elevated temperatures (when using optional temperature-resistant materials). Equipped with double mechanical seal in cartridge design. This allows, in addition to other LABOR-PILOT-modules, the use of the CMS module for easy and dust-free suction of powders into liquids in batch operation. A locking pressure system guarantees safe working even at dry run. Standard execution with module ULTRA-TURRAX UTL. Can be delivered with on/off switch or with PROCESS-PILOT CONTROLLER for variable speed adjustment.

Technical data	IKA® magic LAB® 2000/03
Power supply	230 V / 50 Hz
Motor power	900 W
Temperature long / short time operation	80 °C / 120 °C
Max. process pressure	2.5 bar
Standard rotational speed	14,600 rpm
Adjustable rotational speed range	3,000 – 26,000 rpm
Circumferential speed at 14,600 rpm	23 m/s
Flow capacity (at standard speed)	130 l/h (H ₂ O)
Dimensions basic machine (W x D x H)	170 x 270 x 215 mm
Weight basic machine	7 kg
Dimensions transport box (W x D x H)	350 x 460 x 560 mm
Weight basic machine in transport box	20 kg
	Ident. No. U078310

Technical data	IKA® LABOR-PILOT 2000/04
Power supply	3 x 380 – 420 V / 50 Hz
Motor power	1.5 kW
Max. admissible temperature	120 °C
Max. process pressure	3 bar
Rotational speed	8,050 rpm
Circumferential speed at 50 Hz	23 m/s
Flow capacity	approx. 500 l/h (H ₂ O)
Dimensions (W x D x H)	450 x 250 x 350 mm
Weight	36 kg
Basic unit with on/off switch	Ident. No. U103694
Package including controller	Ident. No. U103695

Technical data	IKA® PROCESS-PILOT 2000/04
Power supply	3 x 380 – 420 V / 50 Hz
Motor power	2.2 kW
Max. admissible temperature	120 °C
Max. process pressure	10 bar
Rotational speed	8,050 rpm
Circumferential speed at 50 Hz	25 m/s
Flow capacity	approx. 500 l/h (H ₂ O)
Dimensions (W x D x H)	425 x 250 x 900 mm
Weight	53 kg
Basic unit with on/off switch	Ident. No. U103696
Package including controller	Ident. No. U103697

Technical data	LABOR-PILOT CONTROLLER
Power	1.5 kW
Frequency range	20 – 87 Hz
Rotational speed range (drive + controller)	3,170 - 13,789 rpm
Circumferential speed (drive + controller)	9.4 - 41 m/s

Technical data	PROCESS-PILOT CONTROLLER
Power	4 kW
Frequency range	20 – 87 Hz
Rotational speed range (drive + controller)	3,170 - 13,789 rpm
Circumferential speed (drive + controller)	9.4 - 41 m/s

Module DISPAX-REACTOR® DR

Three stage dispersing for manufacturing of fine emulsions and suspensions.

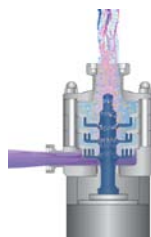

	Module DISPAX-REACTOR® DR		
Dispersing element	magic LAB®	LABOR-PILOT	PROCESS-PILOT
Ident. No.	U078352	T055013	T058133
Flow rate	80 l/h (H ₂ O)	210 l/h (H ₂ O)	210 l/h (H ₂ O)
Standard rotational speed	14,600 rpm	8,050 rpm	8,050 rpm
Circumferential speed*	23 m/s	23 m/s	23 m/s

Module Colloid mill MK

Wet milling by means of spiral gearing milling tool. Production of colloidal solutions (finest suspensions) and emulsions. Adjustable flow rate and friction by setting the gap between the rotor and stator.



	Module Colloid mill MK		
Dispersing element	magic LAB®	LABOR-PILOT	PROCESS-PILOT
Ident. No.	U076662	T057770	T058593
Flow rate**	200 l/h (H ₂ O)	1,500 l/h (H ₂ O)	1,500 l/h (H ₂ O)
Standard rotational speed	14,600 rpm	8,050 rpm	8,050 rpm
Circumferential speed*	23 m/s	23 m/s	23 m/s

Module Cone mill MKO

Wet milling as with the MK module. The cones are furnished with an abrasion resistant tungsten carbide cobalt coating. Narrowest grinding gap enables producing of even finer suspensions.



	Module Cone mill MKO		
Dispersing element	magic LAB®	LABOR-PILOT	PROCESS-PILOT
Ident. No.	U079664	T061623	U069855
Flow rate**	25 l/h (H ₂ O)	75 l/h (H ₂ O)	75 l/h (H ₂ O)
Standard rotational speed	14,600 rpm	8,050 rpm	8,050 rpm
Circumferential speed*	23 m/s	23 m/s	23 m/s

Module CMS

Suction of solids into fluids in the recirculation process. Free from lumps and dust processing of powders and granules. Energy-efficient homogeneous mixing.

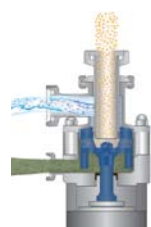

	Module CMS	
Dispersing element	magic LAB®	PROCESS-PILOT***
Ident. No.	U075333	T061819
Flow rate**	1,000 l/h (H ₂ O)	6,500 l/h (H ₂ O)
Standard rotational speed	11,000 rpm	8,050 rpm
Circumferential speed*	19.5 m/s	27 m/s

Module MHD (mixing, homogenising, dispersing)

Continuous mixing and dispersion of powders in liquids. Patented process. Fast and homogeneous mixing in only one passage, avoiding agglomerates. Solids content up to 80 %.



	Module MHD (mixing, homogenising, dispersing)		
Dispersing element	magic LAB®	LABOR-PILOT	PROCESS-PILOT
Ident. No.	U075262	T057351	T058150
Flow rate**	60 l/h (H ₂ O)	200 l/h (H ₂ O)	200 l/h (H ₂ O)
Standard rotational speed	14,600 rpm	8,050 rpm	8,050 rpm
Circumferential speed*	23 m/s	23 m/s	23 m/s

Application Examples

For your customized execution, please contact our sales team:

Tel. +49 7633 831-0
process@ika.com
www.ikaprocess.com



magic LAB® with module Micro-Plant 1 l for recirculation process in the open vessel



magic LAB® with module Micro-Plant 2 l for recirculation process in the closed vessel



magic LAB® with module CMS and accessories for powder incorporation into liquid in recirculation mode



magic LAB® for batch process as ULTRA-TURRAX®

* At standard rotational speed and 50 Hz ** at minimal gap between the rotor and stator*** Only with 4 kW motor.

High Pressure Homogenizer | HPH 2000/04



High energy density and highly turbulent flow at the valve outlet. Particle and droplet size reduction to the nano range. Optimal setting of homogenizing effect by infinite adjustment of the valve gap as well as optional adjustment of the speed. Versions with one or two pistons with correspondingly different capacity are available.

All metal parts in contact with the product are made of stainless steel. The standard version is equipped with an on/off switch. Variable speed control via a HPH CONTROLLER optionally available. Execution acc. to GMP as well as CIP or SIP capability on request.



	HPH 2000/04-SH5	HPH 2000/04-DH5
Technical data		
Power supply	3 x 400 V / 50 Hz	3 x 400 V / 50 Hz
Motor power	1.5 kW	1.5 kW
Max. admissible temperature	60 °C	60 °C
Homogenizing pressure max.	2,000 bar	2,000 bar
Min. feeding volume	10 ml	10 ml
Rotor rotational speed (at 50 Hz)	344 rpm	344 rpm
No. of pistons	1	2
Piston diameter	5 mm	5 mm
Flow rate (H ₂ O)	3 l/h	6 l/h
Dimensions (W x D x H)	311 x 604 x 525 mm	292 x 604 x 607 mm
Weight	36 kg	36 kg
Basic unit with on/off switch	Ident. No. U068906	Ident. No. U071735
Package including HPH controller	Ident. No. T061555	Ident. No. U066126

	HPH CONTROLLER
Technical data	
Power	1.5 kW
Frequency range	20 – 50 Hz
Dimensions (W x D x H)	200 x 310 x 405 mm
Weight	17 kg
	Ident. No. U071728

IKA® laboratory reactors and pilot plants

Achieving a lot while still in the laboratory

Whether you need a system for chemical processes or would like to optimize mixing, dispersing and drying processes, IKA® offers all this in one package.

IKA® laboratory reactor LR-2.ST was designed for usage covering a broad spectrum of process parameters, which you can measure and control. The new IKA® magic PLANT combines diverse mixing technologies as well as innovative drying. The pilot plant Master Plant MP 10 was designed not only for mixing and dispersing, but also for the effective suction of solid and liquid additives. The pilot plant MP 10, as well as the larger IKA® Master Plant production plants, come with a patented scalable dispersing machine, which enables the production of high-quality emulsions and suspensions in just a few passes.

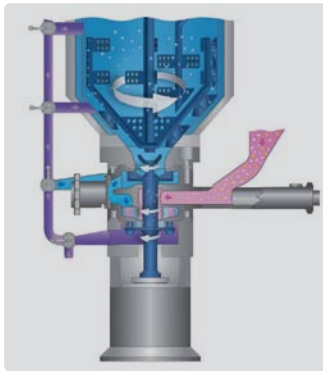

Cross section DBI / Circulation loop



Vacuum and air connection

Spiral agitator

Lifting device

Double walled mixing vessel

Feeding funnel

Dispersing machine DBI

Master Plant MP 10
Mounting example

PROCESS-PILOT CONTROLLER

Circulation loop

Control panel

Outlet

IKA® Master Plant | MP 10



Spiral agitator

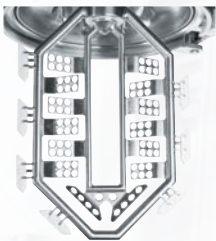

Counter rotating agitator for mixing of high viscous products available



Master Plant MP 10

Ideal and compact laboratory and pilot plant for mixing and dispersing in batch. The innovative patented mixing concept assures the highest product quality and an extreme reduction of the output time.

The Master Plant MP 10 consists of:

- > Heatable/coolable vessel
- > Lifting device for vessel cover together with the stirrer
- > Heatable/coolable agitator with movable scrapers
- > Dispersing machine type DBI 2000/4* that combines pumping, sucking, mixing, dispersing and CIP
- > Circulation loop with selective short or long circuits
- > Feeding funnel for liquid or solid additives with manual piston valve
- > PROCESS-PILOT CONTROLLER

Vertical and horizontal mixing. Infinitely adjustable stirrer and disperser speed. Feeding of solid or liquid additives directly into the dispersing chamber without applying vacuum in the vessel. Dispersing machine with double-acting mechanical seal and choice (valve) between gentle pumping and energy-intensive dispersing. Special Ex-proof version of the system MP 10 on request.

* Machines of type DBI 2000 are separately deliverable for your existing vessels or plants

	MP 10*
Technical data	
Power supply	3 x 400 V / 50 Hz
Useful volume	1.5 – 10 l
Admissible process temperature	-10 up to 150 °C
Max. working vacuum/pressure	10 mbar / 2.5 bar
Max. viscosity	100,000 mPa·s
Frequency range	20 – 60 Hz
Motor power agitator	0.18 kW
Rotational speed range agitator	48 – 144 rpm
Motor power disperser	4 kW
Rotat. speed range disperser	3,160 – 9,480 rpm
Max. flow capacity of the DBI during dispersing	2,000 l/h
Max. flow capacity of the DBI as pump with max. speed	6,000 l/h
Dimensions (W x D x H)	945 x 920 x 1,065 mm
Height with open vessel	1,515 mm
Weight	330 kg
Master Plant MP 10, Version 1 (Vessel with discharge valve, lifting device, spiral agitator)	Ident. No. U098988

Master Plant MP 10, Version 2
(Vessel, lifting device, spiral agitator, dispersing machine DBI, circulation loop, 1 feeding funnel, controller)

Ident. No. U084530

*Also in Ex-protected design deliverable



IKA® laboratory reactors | LR -2. ST

Modular design laboratory reactor for optimization and simulation of various chemical reactions as well as for mixing and homogenizing processes in a laboratory scale.

LR-2.ST laboratory system consisting of:

- > Stand system
- > Laboratory stirring unit EUROSTAR 200 control P4 with high torque
- > Anchor stirrer LR 2000.11 with flow borings
- > Safety shutdown
- > Reactor cover

In the free connections of the reactor cover a dispersing unit (ULTRA-TURRAX®), temperature sensors, flow breakers and other equipment can be installed.

Suitable for vacuum operation. Seals in contact with the product are made of solvent- resp. temperature-resistant perfluoroelastomer (FFPM). Infinitely adjustable speed. Integrated torque trend display for the measurement of viscosity changes. Through control actuated by microprocessor the set speed is held constant, even under load.



Technical data

Min. volume (anchor stirrer)	500 ml
Min. volume (T 25 digital)	800 ml
Max. volume	2,000 ml
Max. working temperature	230 °C
Attainable vacuum	25 mbar
Max. viscosity (EUROSTAR 200 control P4)	150,000 mPa·s
Speed range (EUROSTAR 200 control P4)	0/4 – 530 rpm
Height of telescopic stand	620 – 1010 mm
Dimensions (W x D x H)	460 x 430 x 1.240 mm
Metals in contact with medium	stainless steel (AISI 316L) FFPM borosilicate glass 3.3

LR-2.ST Package 1*

Basic package with reactor cover (sealing material: FFPM) consisting of:

- Stand system LR-2.ST
- LR-2.SI Safety disconnection
- EUROSTAR 200 control P4
- LR 2000.11 Anchor stirrer with flow borings
- LR 2.1 Single-walled reactor vessel

Ident. No. 0009023600

LR-2.ST Package 2

Basic package with reactor cover (sealing material: FFPM) consisting of:

- Stand system LR-2.ST
- LR-2.SI Safety disconnection
- EUROSTAR 200 control P4
- LR 2000.11 Anchor stirrer with flow borings
- LR 2000.1 Double-walled reactor vessel with quick-action connectors

Ident. No. 0009023700

LR-2.ST Package 3

Basic package with reactor cover (sealing material: FFPM) consisting of:

- Stand system LR-2.ST
- LR-2.SI Safety disconnection
- EUROSTAR 200 control P4
- LR 2000.11 Anchor stirrer with flow borings
- LR 2000.2 Double-walled reactor vessel with quick-action connectors and bottom discharge valve

Ident. No. 0009023800

* HBR 4 Heating bath not included in the package.

IKA® LR 1000 System | Hassle free homogenization

LR 1000 basic Package

The LR 1000 basic system enables the operator to stir, heat, cool and control the temperature inside the reactor vessel. The PT 100.5 temperature sensor and the sensor receptacle LR 1000.61 are included with this basic package. Just like its bigger brothers, the LR 2 ST series reactors, the LR 1000 can be adapted to your application by adding accessories for operation under vacuum or for homogenization and dispersing requirements.

LR 1000 control Package

Expanding on the features of the LR 1000 basic, the control model is equipped with a number of additional features that allow even further enhancement of your application requirements. The LR 1000 control can be connected to a PC running with labworldsoft. All measurement data can be monitored and stored conveniently on a PC. The LR 1000 control package also includes the PT 100.5 temperature sensor and the LR 1000.61 sensor receptacle. USB cable is also supplied with this package.



reddot design award
winner 2013

Technical data

Usable volume	400 – 1,000 ml
Max. working temperature	120 °C
Nominal torque	3 Nm
Attainable vacuum	25 mbar
Max. viscosity	100,000 mPas
Speed range	10 – 150 rpm
Display	LED TFT
Heat output	1,000 W
Heat control accuracy	± 1 K
Dimensions (W x D x H)	443 x 295 x 360 mm
Weight	16 kg
Permissible ambient temperature	5 – 40 °C
Permissible relative moisture	80 %

LR 1000 basic | LR 1000 control

LR 1000 basic Package*

	Ident. No.
H 11 Main cable Euro plug	0001091500
LR 1000 basic base	0003600099
LR 1000.1 Reactor vessel	0003602000
LR 1000.61 Sensor receptacle	0004664400
PT 100.5 Temperature sensor	0002506800
LR 1000 basic Package	0008040100

LR 1000 control Package*

	Ident. No.
H 11 Main cable Euro plug	0001091500
LR 1000 control base	0003600099
LR 1000.1 Reactor vessel	0003602000
LR 1000.61 Sensor receptacle	0004664400
PT 100.5 Temperature sensor	0002506800
USB cable USB A-Micro B 2.0	0004335000
LR 1000 control Package	0008040200

* PT 100.5 included in the delivery for measuring the external temperature

IKA® magic PLANT | Most versatile laboratory reactor

IKA® Customization

For application support and information on the extensive accessories, please contact our sales team:

Tel. +49 7633 831-0
process@ika.com
www.ikaprocess.com

The IKA magic PLANT is an ideal laboratory scale process plant. This system is used for batch-wise mixing, homogenizing, emulsifying, in addition to forming sample suspensions for capacities of up to 2 liters. Whether it is involved with the manufacturing of liquids, pastes or powders – the magic PLANT delivers, enabling a seamless transition from product development to production.

- > Modular design
- > Higher viscosity samples can be processed
- > Better heat transfer
- > Ideal for batch/inline/powder operations



magic PLANT basic

- > Perfect mixing and homogenizing of liquids and pastes
- > Tilttable double jacketed and insulated vessel
- > Special stirrer tools are available, such as anchor and propeller stirrers
- > Optional ULTRA-TURRAX® T25 for perfect emulsions and suspensions



magic PLANT inline

- > The latest development in dispersing technology for the finest and most stable emulsions and suspensions
- > Circulation of the product through the circulation loop by the single or three stage rotor-stator system of the connected laboratory dispersing machine magic LAB®
- > Special stirrer tools are available, such as anchor and propeller stirrers



magic PLANT powder

- > Efficient and gentle mixing
- > Special powder agitator
- > Inclined working position for better mixing and drying results
- > Discharge by complete tilting of the vessel

Technical data	magic PLANT basic	magic PLANT inline*	magic PLANT powder
Max. admissible temperature	150 °C	80°C/120°C (long/short time operation)	150 °C
Working pressure range	-1 up to 2.5 bar	-500 mbar up to 2.5 bar	-1 up to 2.5 bar
Useful volume	2 l	2 l	2 l
Stirring tool	anchor or propeller	anchor or propeller	spiral agitator
Speed range	0 – 350 rpm 0 – 2,000 rpm	0 – 350 rpm 0 – 2,000 rpm	0 – 350 rpm -
	Ident. No. 20001186	Ident. No. U107703	Ident. No. U107159

*magic LAB® included in delivery

IKA® Pilotina | Universal 2 in 1 mill for dry products

The IKA® Pilotina can be used for a great variety of milling functions in a diverse range of industrial tasks.



IKA® Pilotina MU

The universal 2 in 1 mill for dry products

Your advantages: one machine, two milling principles, all this without making any compromises with regards to disintegration quality. Due to the powerful, frequency controlled 3 kW drive with digital indication, the circumferential speed of the tool can be adjusted to the required milling process in a way that is optimal for your particular application needs.

IKA® Pilotina MC*

The cutting mill system

The dry mill IKA® Pilotina MC is the pre-eminent choice for the disintegration of smooth, sticky, elastic or fibrous materials such as parts of plants, plastics, food pellets and much more. The design ensures an excellent milling quality, a precisely defined final particle fineness, as well as an easy and quick cleaning after milling.

IKA® Pilotina MI*

The impact milling system

The dry mill IKA® Pilotina MI is the foremost option for the disintegration of hard and brittle materials e.g. coal, glass, ore and/or seeds. The product is disintegrated quickly due to the geometry of the milling space and the fast rotating impact rotor. The final particle fineness can be precisely adjusted via the sieve that is inserted into the milling chamber.

	IKA® Pilotina MU	IKA® Pilotina MC	IKA® Pilotina MI
Technical data			
Motor power	3 kW	1.5 kW	1.5 kW
Speed range	1,500 – 4,500 rpm	1,500 rpm	3,000 rpm
Capacity (depending on the final fineness)	approx. 60 – 80 kg/h	approx. 60 kg/h	approx. 80 kg/h
Circumferential speed	9 – 34 m/s	9 m/s	22 m/s
Dimensions (L x W x H)	495 x 830 x 740 mm	495 x 830 x 670 mm	495 x 660 x 740 mm
Weight, approx.	80 kg	70 kg	70 kg
	Ident. No. U105421	Ident. No. U106466	Ident. No. U106465

* Mounting example on the basis of Pilotina MU

IKA® +

Learn more!

For more information about
our products, please visit:

www.ika.com
www.ikaprocess.com

201411_Pilots_Brochure_EN_EUR_94000315

IKA®-Werke GmbH & Co. KG
Janke & Kunkel-Str. 10
79219 Staufen
Germany

**Laboratory and
Analysing Technology**
Tel. +49 7633 831-0
Fax +49 7633 831-98
sales@ika.de
www.ika.com

Process Technology
Tel. +49 7633 831-0
Fax +49 7633 831-907
process@ika.de
www.ikaprocess.com



IKA® Worldwide

USA

IKA® Works, Inc.
Phone: +1 910 452 7059
process@ikausa.com

China

IKA® Works Guangzhou
Phone: +86 20 8222 1771
Sales-Proc@ika.cn

Malaysia

IKA® Works (Asia) Sdn Bhd
Phone: +60 3 6099-5666
salesprocess@ika.com.my

India

IKA® India Private Limited
Phone: +91 80 2625 3900
process@ika.in

Japan

IKA® Japan K.K.
Phone: +81 6 6730 6781
info@ika.ne.jp

Brasil

IKA® do Brasil
Phone: +55 19 3772-9600
info@ika.net.br

Korea

IKA® Korea. Ltd.
Phone: +82 2 2136 6800
info@ika.kr

